

**SUB-MATHEMATICS, CLASS-X**  
**CHAPTER- (AREAS RELATED TO CIRCLES)**  
**WORSHEET (BASIC)**

---

**(Question No- 1 to 8 are 1 mark questions)**

**Choose the correct option**

1. If  $\theta$  is the angle in degrees of a sector of a circle of radius  $r$ , then area of the sector is  
(a)  $\frac{\pi r^2 \theta}{180}$       (b)  $\frac{\pi r^2 \theta}{360}$       (c)  $\frac{2\pi r \theta}{360}$       (d)  $\frac{2\pi r \theta}{180}$
2. A sector is cut from a circle of radius 21cm and angle of the sector is  $150^\circ$ , the area of the sector is  
(a)  $577.5cm^2$       (b)  $288.2cm^2$       (c)  $152cm^2$       (d)  $155cm^2$

**Fill in the blanks**

3. If the area of the circle is  $154cm^2$ , its perimeter is \_\_\_\_\_.
4. The radius of the circle whose area is equal to sum of areas of the two circles of radii 24cm and 7cm is \_\_\_\_\_.

**Very short answer type questions**

5. What is the area of quadrant of a circle whose radius is 14cm?
6. What is the radius of a circle if its perimeter and area are numerically equal.
7. What is the length of an arc of a circle of radius 7cm, if the angle subtended by it at the center is  $60^\circ$ ?
8. What is the area of a circle if its circumference is 616cm?

**(Question No- 9 to 16 are 2 marks questions)**

**Short answer type question-I**

9. The length of a minute hand of a clock is 14cm. find the area swept by the minute hand in 5 minutes.
10. Find the area of quadrant of a circle whose circumference is 22cm.
11. What is the ratio of area of two circles whose circumference are in ratio 3: 4.
12. A chord of a circle of radius 10cm subtends a right angle at the center. Find the area of the corresponding minor segment.
13. What is the angle subtended at the center of a circle of radius 5cm by an arc of length  $4\pi cm$ ?
14. Find the radius of the circle which can be inscribed in a square of side 6cm.
15. Find the side of the square that can be inscribed in a circle of radius 8cm.

16. If the perimeter of a semicircular protractor is 36 cm, then find its diameter.

**(Question No- 17 to 24 are 3 mark questions)**

**Short answer type question-II**

17. An umbrella has 8 ribs which are equally spaced. Assuming umbrella to be flat circle of radius 45cm, find the area between two consecutive ribs of the umbrella.
18. A chord of a circle of radius 15cm subtends an angle  $60^\circ$  at the center. Find the area of the corresponding minor segment of the circle. (use  $\pi = 3.14, \sqrt{3} = 1.73$ )
19. A horse is tied at one corner of a square grass field by means of 5m long rope. Find the area of the part of the field in which the horse can graze.
20. Find the difference of areas of sector of angle  $90^\circ$  and its corresponding major sector of the circle of radius 21cm.
21. Find the area of a circular ring whose outer and inner radii are 20cm and 15cm respectively.
22. The circumference of a circle is 22cm. find its radius and area.
23. Find the area of the shaded region if radius of two concentric circles are 7cm and 14 cm respectively and  $\angle AOC = 40^\circ$ .

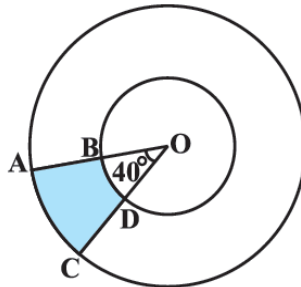

24. A race track is in the form of ring whose outer and inner circumferences are 506m, 440m respectively. Find the width of the track.

**(Question No- 25 to 30 are 4 marks questions)**

**Long answer type question**

25. ABCD is a square of side 14cm. APD and BPC are semicircles. Find the area of shaded region.

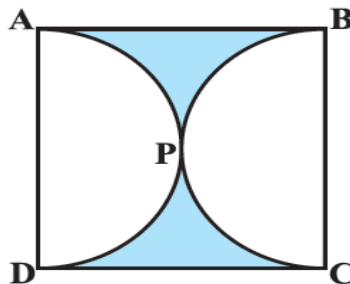

26. Area of circular playground is  $88704m^2$ . Find the cost of fencing this ground at the rate of Rs 65 per metre.
27. In a square ABCD of side 14cm, there are four circles of equal radii. Find the area of shaded region.

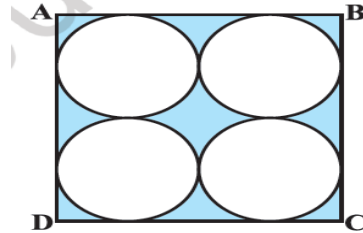

28. The cost of fencing a circular field at the rate of Rs 24 per metre is Rs 5280. Find the area of the field.
29. A chord AB of a circle of radius 10cm makes a right angle at the center of the circle. Find the area of the major and minor segments.
30. A round table cover of radius 28cm has six equal designs. Find the cost of making the designs at the rate of Rs 5 per  $cm^2$ .

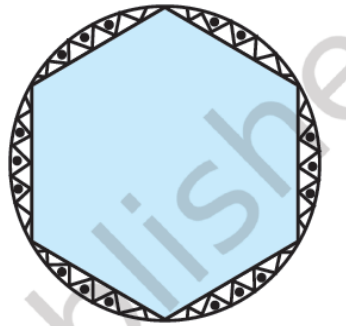

**SUB-MATHEMATICS, CLASS-X**  
**CHAPTER- (AREAS RELATED TO CIRCLES)**  
**WORSHEET (STANDARD)**

---

**(Question No- 1 to 6 are 1 mark questions)**

**Choose the correct option**

1. If sum of areas of two circles with radii  $R_1$  and  $R_2$  is equal to area of a circle of radius  $R$ , then  
(a)  $R_1 + R_2 = R$     (b)  $R_1^2 + R_2^2 = R^2$     (c)  $R_1 + R_2 < R$     (d)  $R_1^2 + R_2^2 < R^2$
2. The area of a circle that can be inscribed in a square of side 6cm is  
(a)  $36\pi cm^2$     (b)  $18\pi cm^2$     (c)  $12\pi cm^2$     (d)  $9\pi cm^2$

**Fill in the blanks**

3. The area of largest triangle that can be inscribed in a semicircle of radius  $r$  is \_\_\_\_\_.
4. The length of an arc (in terms of  $\pi$ ) that subtends an angle of  $36^\circ$  at the center of a circle of radius 5cm is \_\_\_\_\_.

**Very short answer type questions**

5. If the diameter of a semicircular protractor is 14cm, then find its perimeter.
6. A wire is bent to form a circle of radius 35cm. if it is bent in the form of a square, then what will be its area ?

**(Question No- 7 to 12 are 2 marks questions)**

**Short answer type question-I**

7. If the perimeter of a circle is equal to that of a square, then find ratio of their areas.
8. The area of sector of a circle is  $\frac{5}{8}$ th area of a circle, then find the central angle of the sector.
9. Find the diameter of a circle whose area is equal to sum of areas of two circles of diameters 20cm and 48cm.
10. Area of sector of a circle of radius 36cm is  $54\pi cm^2$ . Find the length of the corresponding arc of the circle.
11. The circumference of a circle exceeds the diameter by 16.8cm. Find the radius of the circle.
12. If the perimeter of a circle is numerically equal to the area of the circle, then find the radius of the circle.

**(Question No- 13 to 16 are 3 marks questions)**

**Short answer type question-II**

13. The wheel of motorcycle is of radius 35cm. How many revolutions per minute must the wheel make so as to keep a speed of 66km/hr.
14. ABC is a quadrant of a circle of radius 20cm. With BC as the diameter a semicircle is drawn. Find the area of the shaded region.

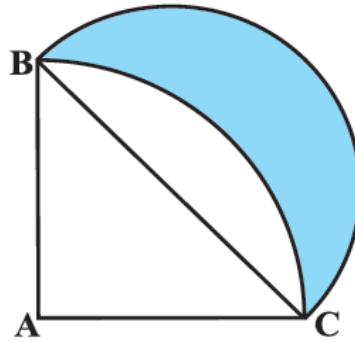

15. Floor of a rectangular room of dimension  $5m \times 4m$  is covered with circular tiles of dimension 50cm each. Find the area of the floor that remains uncovered with the tiles.
16. With vertices A, B and C of a  $\Delta ABC$  as centers arcs are drawn with radii 6cm each. If  $AB = 20cm$ ,  $BC = 48cm$  and  $AC = 52cm$ , find the area of the shaded region.

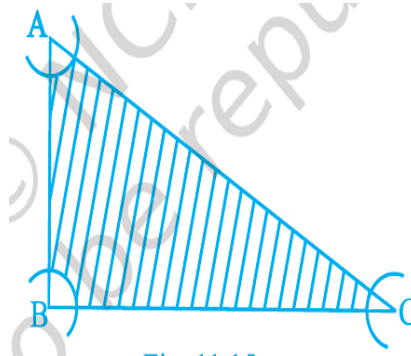

**(Question No- 17 to 20 are 4 marks questions)**

**Long answer type question**

17. Four cardboard pieces of radii 7cm are placed on a paper in such a way that each piece touches other two pieces. Find the area of the portion enclosed between these pieces.
18. ABCD is a square of side 10cm and semicircles are drawn with each side of the squares as diameters. Find the area of the shaded region.(use  $\pi = 3.14$ )

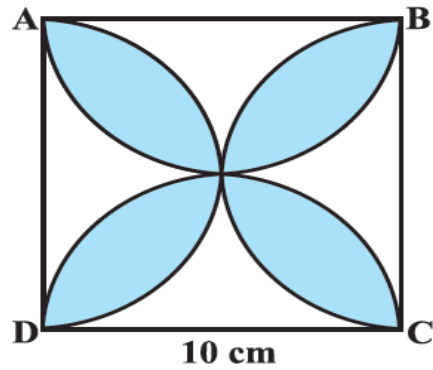

19. In a circular table cover of radius 32 cm, a design is formed leaving an equilateral triangle ABC in the middle as shown in the figure. Find the area of the design.



20. Find the area of the shaded region. ABCD is a rectangle of dimension  $26\text{ m} \times 12\text{ m}$ .

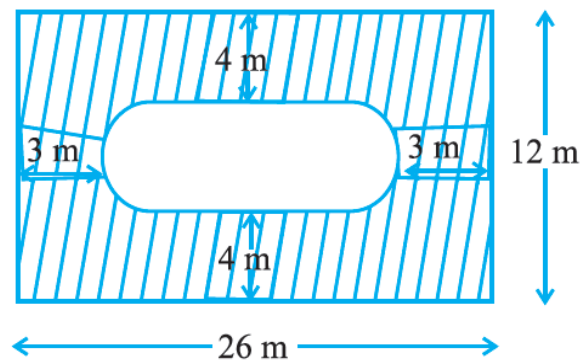

**SUB-MATHEMATICS, CLASS-X**  
**CHAPTER- (AREAS RELATED TO CIRCLES)**  
**WORSHEET (ADVANCED)**

---

**(Question No- 1 to 4 are 1 mark questions)**

**Choose the correct option**

1. A circle is inscribed in a square and another circle is circumscribing the square, the ratio of areas of outer circle to the inner circle is  
(a)  $\sqrt{2}:1$                       (b) 3:1                      (c) 2:1                      (d)  $\sqrt{3}:1$
2. Two circles touch each other externally. The sum of their areas is  $130\pi \text{ cm}^2$  and distance between their center is 14cm. which of the following is false.  
(a) Radius of larger circle is 11cm  
(b) Difference between their radii is 7cm  
(c) Radius of smaller circle is 3cm  
(d) Difference between their area is  $112\pi \text{ cm}^2$

**Very short answer type questions**

3. What is the area of the incircle in an equilateral triangle of side 42cm?
4. If difference between circumference and radius of a circle is 37cm, then what is the area of the circle?

**(Question No- 5 to 6 are 2 marks questions)**

**Short answer type question-I**

5. All the vertices of a rhombus lie on a circle. Find area of the rhombus, if area of the circle is  $1256 \text{ m}^2$ .
6. Two circles of different radii touch internally. The sum of their areas is  $116\pi \text{ cm}^2$  and distance between their center is 6cm. Find the radii of the circles.

**(Question No- 7 to 8 are 3 marks questions)**

**Short answer type question-II**

7. In the given figure,  $\triangle ABC$  is a right angle triangle with  $\angle A = 90^\circ$ ,  $AB=3\text{cm}$ ,  $AC=4\text{cm}$ . Semicircles are drawn on  $AB$ ,  $AC$  and  $BC$  as diameters. Find the area of shaded region.

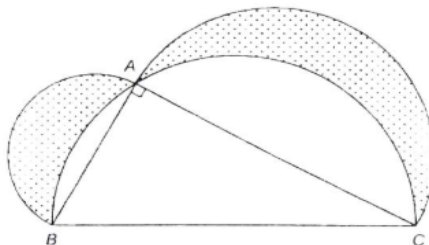

8. It is proposed to add two circular ends, to a square lawn whose side measures 58cm, the center of each circle being a point of intersection of the diagonal of the square. Find the area of the whole lawn.

**(Question No- 9 to 10 are 4 marks questions)**

**Long answer type question**

9. An elastic belt is placed round the rim of the pulley of radius 5cm. one point on the belt is pulled directly from the center O of the pulley until it is at point P, 10 cm from O. Find the length of the belt that is in contact with rim of the pulley. Also find the area of the shaded region.

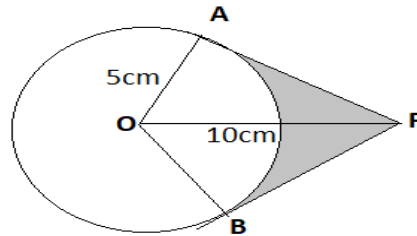

10. In the given figure A and B are two arcs. Arc A is the part of the circle with center O and radius OP. Arc B is the part of a circle with center M and radius PM, where M is the midpoint of PQ. Prove that area enclosed by two arcs is equal to  $25 \left( \sqrt{3} - \frac{\pi}{6} \right) cm^2$ .

